



Swimming Pools Building & Zoning Requirements

11800 Town Center Drive NE, Suite 300 St. Michael, MN 55376

Phone: (763) 497-2041 Email: planning@stmichaelmn.gov

DEFINITION: Swimming pool means any pool, tank, depression or excavation in or above ground, or other structure which shall cause or has the capacity to retain water with a depth greater than 30 inches, which shall be designed for the intent to be used for swimming, wading or immersion purposes by individuals.

PERMIT REQUIRED:

No person shall construct, alter or renovate a swimming pool without an approved permit.

The application for a permit must include the following:

- a. Complete plans and specifications for the construction of the pool.
- b. A site plan showing the distance of the proposed swimming pool from the property lines, existing structures on the lot, including the house, garage, and fences, retaining, walls, trees, overhead and underground wiring, utility easements, any on-site sewer systems and other significant features.
- c. The proposed location of the pumps, filters, motors, electrical power source, flushing and drainage outlets, and other operational features.
- d. Location and specifications of protective fencing, including any construction fence for in-ground pools. Must include a signed fencing agreement.

REQUIRED INSPECTIONS:

1. Location. When the pool location has been staked to ensure it meets setbacks.
2. Footing. When the pool has been dug and forms have been erected.
3. Final. When the pool and pool enclosure have been installed.

LOCATION (SETBACKS):

1. Swimming pools shall not be located beneath utility lines or over underground utility lines of any type.
2. No person, firm or corporation shall build, situate or install a swimming pool within ten feet (10') of any side property line and fifteen feet (15') from any rear property line, nor within ten feet (10') of any principal structure, excluding uncovered decks. Swimming pools cannot be located closer to the front property line than the principal structure. Corner lots are permitted to install swimming pools within the 'front yard' that is opposite the interior side yard, but must meet the required front yard setback.
3. No swimming pool shall be located within ten feet (10') of any portion of a septic tank or within twenty feet (20') of any area designated as a drainfield, alternate drainfield or well.
4. No pool shall be located within a public or private utility easement, ingress or egress easement, swale, existing drainage areas which may be affected by 100 year rain event levels, wetlands, floodplains or other location in which it will represent a threat to the natural environment.



Please Note: All existing above-ground swimming pools must conform to the fence requirements listed below

FENCE REQUIREMENTS COMMON TO ALL SWIMMING POOLS:

1. The fence shall be of the non-climbing type, so as not to be penetrable by toddlers and afford no external handholds or footholds.
2. The bottom of the fence shall be no higher than four inches (4") above grade at any given point.
3. All fence openings or points of entry into the pool area enclosure shall be equipped with self-closing and self-latching gates. The self-latching device must be placed at the top of the gate or so it is inaccessible to small children.
4. Fences must be setback from the swimming pool a distance equal to or greater than the height of any above-ground swimming pool.
5. Required fencing must be located on top of any retaining wall or no closer than 4 feet from the bottom of any retaining wall, unless otherwise approved by the Zoning Administrator.
6. Fences shall be constructed in a workmanlike manner and of cut lumber, brick, fieldstone, wrought iron, maintenance free PVC (poly Vinyl Chloride), Chain link (with a minimum thickness of gauge 11 and a required top rail support), stockade or board-on-board wood. **Barbed wire and temporary mesh fencing shall not be permitted.**
7. All fences shall be constructed of steel or wood posts properly supported and braced by top rails that shall be located on the inside of the fence.

SPECIFIC:

1. Construction Fence. A construction fence shall completely enclose any in-ground pool prior to the erection of a permanent fence described in §155.054 (D). The construction fence shall be a minimum of six feet (6') in height, made of snow fence or similar design and be securely anchored in place with its base flush to the ground. It must have supportive posts placed no more than eight feet (8') apart and remain in place until a permanent fence completely enclosing the swimming pool is installed. No swimming pool, even though containing water for construction purposes, shall be occupied or used at anytime prior to the installation of a permanent fence.
2. In-ground Pools. A fence at least six feet (6') in height shall completely enclose any in-ground swimming pool.
3. Above-ground Pools. A fence at least four feet (4') in height shall completely enclose any above-ground swimming pool.
4. Above-ground Pools with Accessory Decks. If an accessory deck is constructed within three feet (3') of any part of the above-ground swimming pool, the deck shall be required to include a minimum 36 inch (36") high guard rail. The guard rail shall be constructed so no space within it is wider than four inches (4"). All openings or points of entry into the above-ground pool shall be equipped with self-closing and self-latching gates.
5. Outdoor Spas & Hot Tubs. Outdoor spas and hot tubs of any size must be covered when not in use and shall have a latchable cover or surrounded by a four foot (4') non-climbing fence. The cover should be constructed of a material not to be penetrable by toddlers, and is subject to inspection by the Building official or designee.

FENCES FOR SWIMMING POOLS:

The figures below illustrate various options of fencing required for swimming pools:

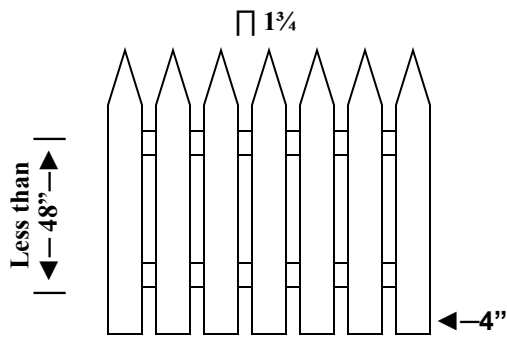

IF HORIZONTAL MEMBERS ARE LESS THAN 48 INCHES APART, SPACING SHALL NOT EXCEED $1\frac{3}{4}$ INCHES.

72"

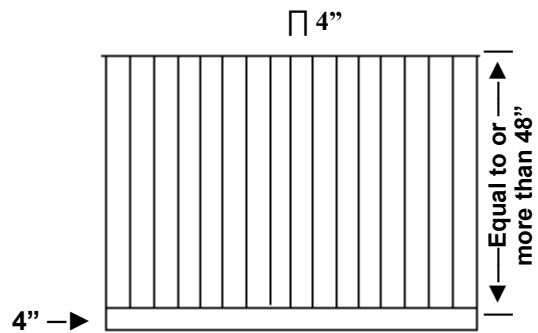

IF HORIZONTAL MEMBERS ARE EQUAL TO OR MORE THAN 48 INCHES APART, SPACING SHALL NOT EXCEED 4 INCHES.

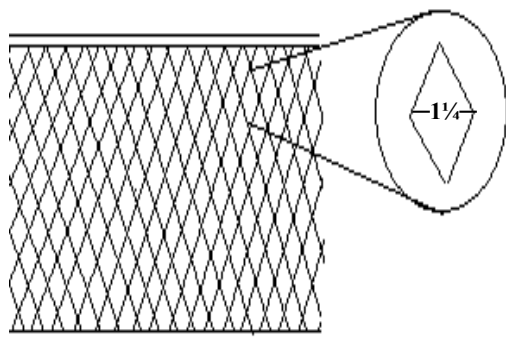

$1\frac{1}{4}$ INCH SQUARE MESH (MINI-MESH) IS REQUIRED AROUND ALL IN-GROUND POOLS. STANDARD CHAINLINK FENCING IS PERMITTED FOR ABOVE-GROUND POOLS.

72"

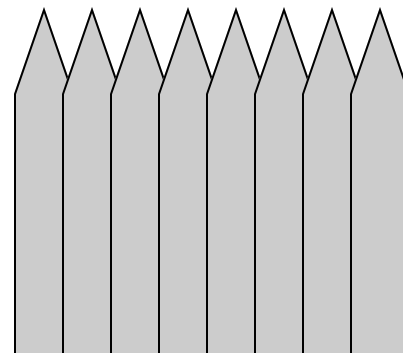

WOOD-BOARD ON BOARD FENCE

ADDITIONAL INFORMATION:

1. Conduct. The conduct of persons and the operation of pools is the responsibility of the owner or the tenant thereof, and such conduct of persons and operation of the pool shall be done in such a manner so as to avoid any nuisance or breach of peace, and it shall be unlawful to allow loud noise to go beyond the boundaries of the property upon which the pool is located to adjacent property.
2. Drainage. All back flushing water or pool drainage water shall be directed onto the property of the owner or onto approved drainage ways, such as street curb, ditches, storm sewers and storm water ponds.
3. Lighting. Any outdoor lighting of the pool may not spill or shine upon adjacent properties. For all underground pool lights and above-ground plug in motors, compliance with Electrical Code is required.

For additional City Information, please check the website or contact City Hall at:
11800 Town Center Drive NE, Suite 300, St. Michael, MN 55376
Phone: 763-497-2041 Email: planning@stmichaelmn.gov
www.stmichaelmn.gov