



Fencing Agreement For A Swimming Pool Permit

11800 Town Center Drive NE, Suite 300 St. Michael, MN 55376
Phone: (763) 497-2041 Email: planning@stmichaelmn.gov

PERMIT #: _____

DATE: _____

PROPERTY ADDRESS: _____

WHAT FOLLOWS ARE THE REQUIREMENTS FOR FENCES AROUND POOLS. BY SIGNING THIS, YOU ARE CONFIRMING THAT YOU HAVE READ THESE REQUIREMENTS AND RECEIVED A COPY OF THIS AND WILL COMPLY WITH THEM BEFORE ADDING WATER TO YOUR POOL.

REGUALTIONS FOR ALL SWIMMING POOLS:

1. The fence shall be of the non-climbing type, so as not to be penetrable by toddlers and afford no external hand-holds or footholds.
2. The bottom of the fence shall be no higher than four inches (4") above grade at any given point.
3. All fence openings or points of entry into the pool area enclosure shall be equipped with self-closing and self-latching gates. The self-latching device must be placed at the top of the gate or so it is inaccessible to small children.
4. Fences must be setback from the swimming pool a distance equal to or greater than the height of any above-ground swimming pool.
5. Required fencing must be located on top or a minimum of four feet from the edge of any retaining wall when the pool is lower than the retaining wall.
6. Fences shall be constructed in a workmanlike manner and of cut lumber, brick, fieldstone, wrought iron, maintenance free PVC (Poly Vinyl Chloride), Chain link (with a minimum thickness of gauge 11 and a required top rail support), stockade or board-on-board wood. Barbed wire and temporary mesh fencing shall not be permitted.
7. All fences shall be constructed of steel or wood posts properly supported and braced by top rails that shall be located on the inside of the fence.

SPECIFIC:

1. **Construction Fence.** A construction fence shall completely enclose any in-ground pool preceding the erection of a permanent fence described in division (D)(1). The construction fence shall be a minimum of six feet in height, made of snow fence-like or similar design and be securely anchored in place with its base flush to the ground. It must have supportive posts placed no more than eight feet apart and remain in place until a permanent fence completely enclosing the swimming pool is installed. No swimming pool, even though containing water for construction purposes, shall be occupied or used at any time prior to the installation of a permanent fence.
2. **In-ground Pools.** A safety fence at least six feet in height shall completely enclose any in-ground swimming pool. As an alternative to a safety fence, an automatic pool cover may be utilized if it meets the standards of F1346-91 (reapproved 1996) of American Society of Testing and Materials (ASTM), as such standards may be modified, superseded, or replaced by ASTM, if all of the following requirements are met:
 - (a) The property on which the in-ground pool is located is zoned A-1 Agricultural;
 - (b) The property upon which the in-ground pool is located does not abut a residential zoning district;
 - (c) The property upon which the in-ground pool is located is five acres or larger in area;
 - (d) The in-ground pool is set back a minimum of 150 feet from the side and rear property lines and 300 feet from an existing non-owner occupied dwelling. The 150-foot setback may be waived if the side or rear lot line of the parcel upon which the in-ground pool is located is adjacent to a public body of water as identified on the Minnesota DNR Public Water Inventory Map and the required minimum shoreland setbacks are met.
3. **Above-ground Pools.** A fence at least four feet (4') in height shall completely enclose any above-ground swimming pool.
4. **Above-ground Pools with Accessory Decks.** If an accessory deck is constructed within three feet (3') of any part of the above-ground swimming pool, the deck shall be required to include a minimum 36 inch (36") high guard rail. The guard rail shall be constructed so no space within it is wider than four inches (4"). All openings or points of entry into the above-ground pool shall be equipped with self-closing and self-latching gates.

FENCES FOR SWIMMING POOLS:

The figures below illustrate various options of fencing required for swimming pools:

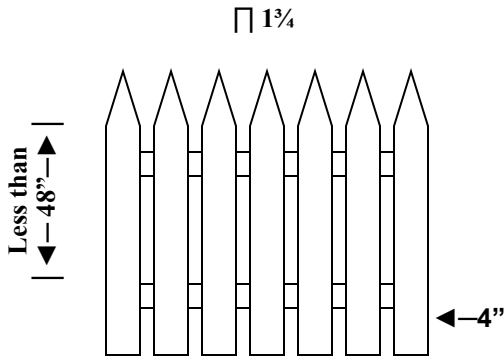

IF HORIZONTAL MEMBERS ARE LESS THAN 48 INCHES APART, VERTICAL SPACING SHALL NOT EXCEED 1³/₄ INCHES.

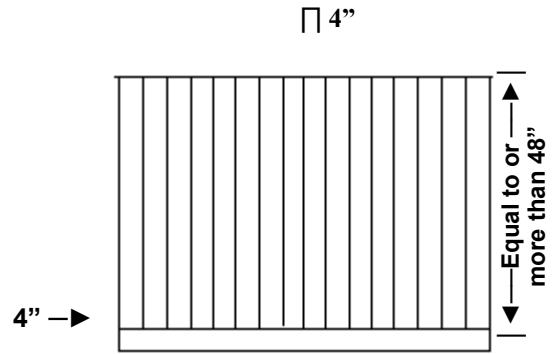

IF HORIZONTAL MEMBERS ARE EQUAL TO OR MORE THAN 48 INCHES APART, VERTICAL SPACING SHALL NOT EXCEED 4 INCHES.

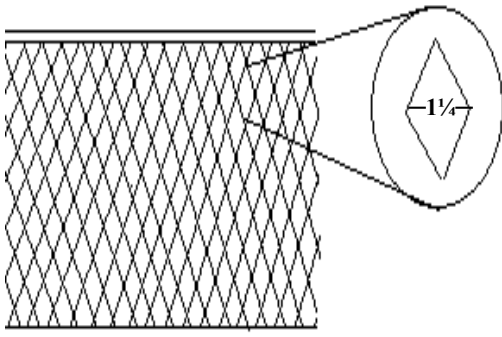

1¹/₄ INCH SQUARE MESH (MINI-MESH) IS REQUIRED AROUND ALL IN-GROUND POOLS. STANDARD CHAINLINK FENCING IS PERMITTED FOR ABOVE-GROUND POOLS.

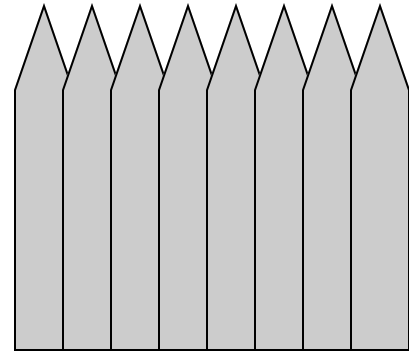

WOOD-BOARD ON BOARD FENCE

ADDITIONAL INFORMATION:

1. Conduct. The conduct of persons and the operation of pools is the responsibility of the owner or the tenant thereof, and such conduct of persons and operation of the pool shall be done in such a manner so as to avoid any nuisance or breach of peace, and it shall be unlawful to allow loud noise to go beyond the boundaries of the property upon which the pool is located to adjacent property.
2. Drainage. All back flushing water or pool drainage water shall be directed onto the property of the owner or onto approved drainage ways, such as street curb, ditches, storm sewers and storm water ponds.
3. Lighting. Any outdoor lighting of the pool may not spill or shine upon adjacent properties. For all underground pool lights and above-ground plug in motors, compliance with Electrical Code is required.

Submit form to planning@stmichaelmn.gov.

Type of Pool Being Installed: _____

Type of Fence/Pool Cover Being Installed: _____

Signature of Owner: _____ Date: _____